

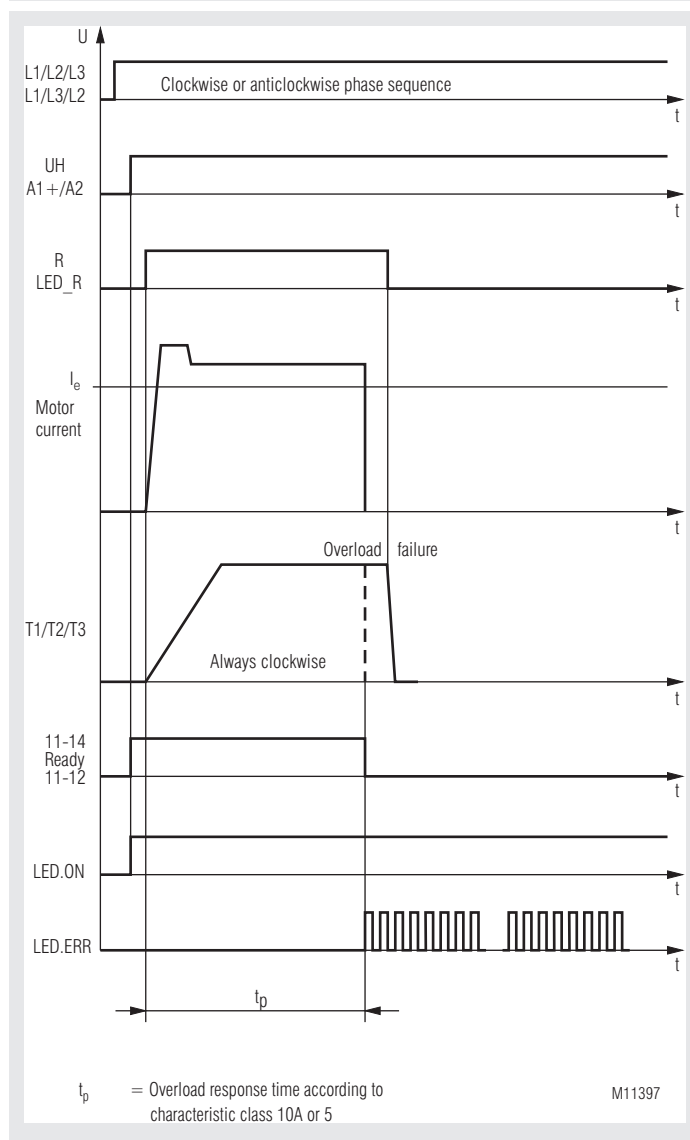

Product Description

The smart motorstarter UG 9256/804 and UG 9256/807 is used to provide always a clockwise phase sequence and to start asynchronous motors. Independent of the the phase sequence on the input it will always provide clockwise sequence on the output to the motor. The unit also protects the motor against phase failure and motor overload. The relays of the reversing circuit switch without current. This provides a long electrical life. To reduce the motor starting current and protect the drive, the motor starter is equipped with a fixed soft start function.

Function diagram



Your Advantages

- Up to 4 functions in one unit
 - Providing clockwise phase sequence at the motor connection terminals
 - Phase failure detection
 - Motorprotection Class 10 A, Class 5
 - Softstart
- Galvanic mains separation by forcibly guided contacts contact opening min. 0.5 mm (UG 9256/807)
- 66 % less space
- Simple and time-saving commissioning as well as user-friendly operation through setting via potentiometer on absolute scale
- Hybrid relay combines benefits of relay technology with non-wearing semiconductor technology
- High availability by
 - Temperature monitoring of semiconductors
 - High withstand voltage up to 1500 V
 - Load free relay reversing function

Features

- According to UL 60947-4-2, IEC/EN 60947-4-2
- To reverse the rotary field
- For 3-phase motors with rated motor current from I_e 0.1 A ... 0.5 A or 0.5 ... 2 A or 1.5 A ... 9 A
- 1 potentiometer für setting of rated motor current
- 3 LEDs for status indication
- Reversing with relays without current, switching with thyristor
- Galvanic separated 24V-inputs for clockwise
- Reset button on front
- Connection facility for external reset button
- Relay indicator output for operation
- Galvanic separation between control circuit and power circuit
- Galvanic separation of motor terminals from mains voltage in off state or fault condition (UG 9256/807)
- Width 22.5 mm

Approvals and Markings



^{*)} 9 A-variants

Application

- Conveyor systems with preferred direction of rotation
- Actuating drives in process controls with preferred direction of rotation

Circuit Diagrams

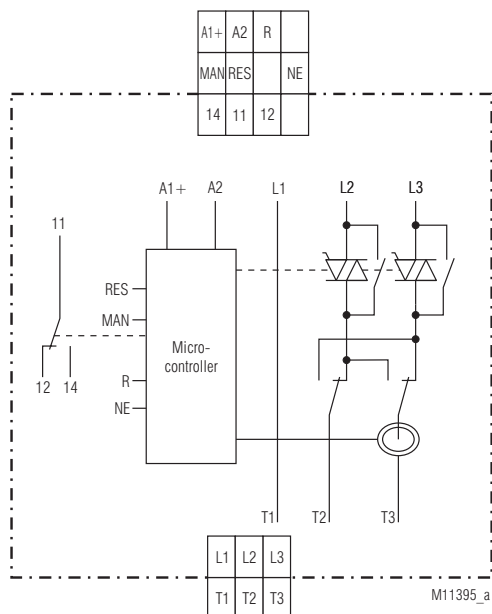

UG 9256/804

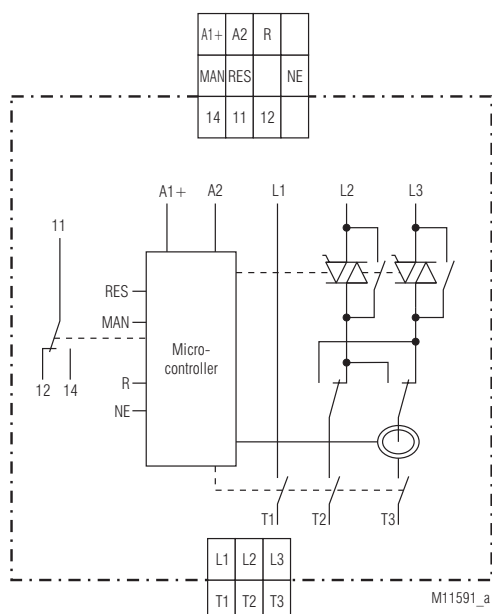

UG 9256/807

Connection Terminals

Terminal designation	Signal description
A1 (+)	Auxiliary voltage + DC 24 V
A2	Auxiliary voltage 0 V
R+	Control input clockwise
NE	Earth connection control input
MAN	Output for remote reset
RES	Input for remote reset
11, 12, 14	Indicator relay for operation
L1	Phase voltage L1
L2	Phase voltage L2
L3	Phase voltage L3
T1	Motor connection T1
T2	Motor connection T2
T3	Motor connection T3

Functions

Motor protection

The thermal load of the motor is calculated using a thermal model. To calculate the thermal load the current is measured in phase T3.

A symmetric current load of all 3 phases of the motor is assumed for flawless functioning. When the trigger value – stored in the trigger characteristics -, is reached, the motor is switched off and the device switches to fault 8. The fault can be acknowledged via the reset button or reset input.

Attention: The data of the thermal model is cleared through reset or voltage failure. In this case, the user must provide adequate cooling time of the motor.



Phase failure

To make sure the motor is not loaded with asymmetric currents, a check takes place during motor start whether phases L1, L2 and L3 are present. If one or several phases are absent, the device switches to fault 4. The fault can be acknowledged via the reset button or reset input.

Phase failure is detected when the phase is missing for at least 1 second.

Soft start

Two motor phases are impacted through thyristor phase-fired control to allow a steady increase of the currents. The motor torque behaves in the same manner when ramping up. This ensures that the drive can start without jerking and the drive elements are not damaged. The soft starter parameters are fixed.

Motor connection (UG 9256/807)

In off state or fault condition the motor terminals are isolated from the mains voltage by a 4 pole, forcibly guided contact relay. The contact opening is min. 0.5 mm

Control input R+

Clockwise rotation can be selected via one control input R+. The reference connection for the control input is the terminal NE. The control input is galvanically separated from the rest of the unit.

Signalling output "Ready"

Contact 11/14 is closed if no device fault is present.

Indication

Green LED "ON": Permanent on - Auxiliary supply connected

Yellow LED "R": Permanent on - Clockwise, power semiconductors bridged

Red LED "ERR": Short impulse - Phase reversal detected (note)

Red LED "ERR": Flashing - Device fault

- 1*) - Overtemperature on semiconductors
- 2*) - Wrong mains frequency
- 4*) - Incorrect synchronisation signal
- 6*) - Mains isolating energized
- 7*) - Incorrect temperature measurement circuit
- 8*) - Motor protection has responded

1*) - 8*) = Number of flashing pulses in sequence

Reset Function

2 options are available to acknowledge the fault

Manual (reset button):

Acknowledgement is performed by operating the reset button at the front of the device. If the button is still actuated after 2 seconds, the device resumes the fault state.

Manual (remote acknowledgement):

Remote acknowledgement can be realised by connecting a button (N/O contact) between the terminals MAN and RES. Acknowledgement is triggered as soon as the contact of the button closes. If the button is still actuated after 2 seconds, the device resumes the fault state since a defect in the acknowledgement circuit cannot be ruled out.

Setting Facilities

Rotary switch I_e: - Nom. motor current 1.5 A_{eff} ... 9.0 A_{eff}

Set-up Procedure

1. Connect motor and device according to application example.
The unit works with clockwise or anticlockwise phase sequence.
2. Adjust the nominal current of the connected motor with potentiometer I_e
3. Connect device to power and start motor via control input R.



Safety Notes



Installation Error!

- For engine control units, the minimum loads indicated in the data sheet must be observed.

- The use of capacitive loads can lead to the destruction of switching components of the motor control unit. Do not operate capacitive loads on the motor control unit.



Although the motor is at standstill, it is not galvanically separated from the mains.



Group supply:

If several motorstarters are protected together, the sum of the motor currents must not exceed 25 A.



For reliable operation the auxiliary supply DC 24 V has to be continuously available during operation and should only be switched off not before 1 sec after the load voltage has been disconnected. Voltage dips of the auxiliary supply with load on Output T1, T2, T3 can lead to higher wearing of the relays or even to damage of the device.



Functional error!

Danger to life, risk of serious injuries or property damage.

- It must be ensured that the motor start signal is removed before the reset, otherwise the motor will start again.

Mounting Notes

When operated with rated continuous current the devices must not be placed closer than 10 mm side-by-side.

The phase current in the device is measured with a hall effect sensor. Due to this principle also magnetic fields next to the sensor may have an influence. When designing circuits with this motorstarter components that generate magnetic fields like contactors, transformers, high current wires should not be placed close to the sensor.

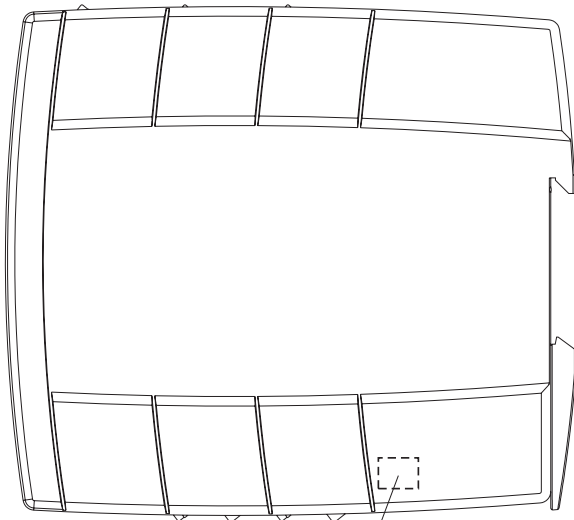

M11633

Position of the current sensor

Technical Data

	Rated current 0.5 A (on request)	Rated current 2 A	Rated current 9 A
Nominal voltage L1/L2/L3:	3 AC 200 ... 480 V ± 10 %		
Nominal frequency:	50 / 60 Hz, automatic detection		
Auxiliary voltage:	DC 24 V ± 10 %		
Max. motor power at AC 400 V:	150 W	0.75 kW	4 kW
Min. motor power:	30 W	90 W	550 W
Operating mode:	AC 51 AC 53a: 6-2: 100-30 IEC/EN 60947-4-2		
Soft start voltage:	50 % (other on request)		
Soft start time:	500 ms (other on request)		
Surge current:	200 A (t _p = 20 ms)		
Load limit integral:	200 A ² s (t _p = 10 ms)		
Peak reverse voltage:	1500 V		
Overvoltage limiting:	AC 550 V		
Leakage current in off state:	< 3 x 0.5 mA		
Consumption:	2 W		
Start up delay for master tick:	Min. 100 ms		
Release delay for master tick:	Min. 50 ms		
Measuring accuracy:	± 5 % of end of scale value		
Measured value update time			
at 50 Hz:	100 ms		
At 60 Hz:	83 ms		
Motor protection			
I _e 0.1 A to 0.5 A:	Class 10 A	-	-
I _e 0.5 A to 2.0 A:	-	Class 10 A	-
I _e 1.5 A to 6.8 A:	-	-	Class 10 A
I _e 6.9 A to 9.0 A:	-	-	Class 5
	Electronically, without thermal memory		
Reset:	Manual		
Short circuit strength			
max. fuse rating:	25 A gG / gL IEC/EN 60947-5-1		
Coordination type:	1		



Coordination Type!

Coordination type 1 according to IEC 60947-4-1: The engine control unit is defective following a short circuit and must be replaced.

Electrical life:	> 10 x 10 ⁶ switching cycles
-------------------------	---

Inputs

Control input right:	DC 24 V
Rated current:	4 mA
Response value ON:	DC 10 V ... 30 V
Response value OFF:	DC 0 V ... 8 V
Connection:	Polarity protected diode
Manual:	DC 24 V (connect button on terminals "MAN" and "RES")
RES:	DC 24 V, semiconductor, short circuit proof, rated continuous current 0.2 A

Indicator Outputs

Ready:	Changeover contact 250 V / 5 A
Contact:	1 Changeover contact
Switching capacity	
to AC 15	
NO contact:	3 A / AC 230 V IEC/EN 60947-5-1
NC contact:	1 A / AC 230 V IEC/EN 60947-5-1
Thermal current I_{th}:	5 A
Electrical life	
to AC 15 at 3 A, AC 230 V:	2 x 10 ⁵ switch. cycles IEC/EN 60947-5-1
Mechanical life:	15 x 10 ⁶ switching cycles
Permissible switching frequency:	1800 switching cycles/h
Short circuit strength	
Max. fuse rating:	4 A gG / gL IEC/EN 60947-5-1

Technical Data

General Data

Device type: Hybrid Motor Controller H1B
Operating mode: Continuous operation
Temperature range:
Operation: 0 ... + 60 °C (see derating curve)
At an altitude of > 2000 m the maximum permissible temperature reduces by 0.5 °C / 100 m

Storage: - 25 ... + 75 °C
Relative air humidity: 93 % at 40 °C
Altitude: ≤ 2000 m

Clearance and creepage distances

Rated insulation voltage: 500 V
Overvoltage category / contamination level between control input-, auxiliary voltage and Motor voltage respectively indicator contact: 4 kV / 2 IEC/EN 60664-1
Overvoltage category: III

EMC

Interference resistance

Electrostatic discharge (ESD): 8 kV (air) IEC/EN 61000-4-2
HF-irradiation
80 MHz ... 1.0 GHz: 10 V / m IEC/EN 61000-4-3
1.0 GHz ... 2.5 GHz: 3 V / m IEC/EN 61000-4-3
2.5 GHz ... 2.7 GHz: 1 V / m IEC/EN 61000-4-3
Fast transients: 2 kV IEC/EN 61000-4-4
Surge voltage between wires for power supply: 1 kV IEC/EN 61000-4-5
Between wire and ground: 2 kV IEC/EN 61000-4-5
HF-wire guided: 10 V IEC/EN 61000-4-6
Voltage dips: IEC/EN 61000-4-11

Interference emission

Wire guided: Limit value class B IEC/EN 60947-4-2
Radio irradiation: Limit value class B IEC/EN 60947-4-2

Degree of protection:

Housing: IP 40 IEC/EN 60529
Terminals: IP 20 IEC/EN 60529

Vibration resistance:

Amplitude 0.35 mm
frequency 10 ... 55 Hz, IEC/EN 60068-2-6
0 / 060 / 04 IEC/EN 60068-1
DIN 46228-1/-2/-3/-4

Climate resistance:

Wire connection:

Screw terminal (fixed):

Control terminals

Cross section: 1 x 0.14 ... 2.5 mm² solid or stranded wire with sleeve

Power terminals

Cross section: 1 x 0.25 ... 2.5 mm² solid or stranded wire with sleeve

Insulation of wires or sleeve length: 8 mm

Fixing torque: 0.5 Nm

Wire fixing: Captive slotted screw

Mounting: DIN rail IEC/EN 60715

Weight: 220 g

Dimensions

Width x height x depth: 22.5 x 105 x 120.3 mm

UL-Data (9 A-variants)

Standards:

For all products:

- U.S. National Standard UL508, 17th Edition
- Canadian National Standard - CAN/CSA-22.2 No. 14-13, 12th Edition

With restrictions at motor switching power:

- ANSI/UL 60947-1, 3rd Edition (Low-Voltage Switchgear and Controlgear Part1: General rules)
- ANSI/UL 60947-4-2, 1st Edition (Low-Voltage Switchgear and Controlgear Part 4-2: Contactors and Motor-Starters - AC Semiconductor Motor Controllers and Starters)
- CAN/CSA-C22.2 No. 60947-1-07, 1st Edition (Low-Voltage Switchgear and Controlgear - Part1: General rules)
- CSA-C22.2 No. 60947-4-2-14, 1st Edition (Low-Voltage Switchgear and Controlgear - Part 4-2: Contactors and Motor-Starters - AC Semiconductor Motor Controllers and Starters)

Motor data:

UL 508, CSA C22.2 No. 14-13

3 AC 200 ... 480 V,

3-phase, 50 / 60 Hz: Up to 7.6 FLA, 45.6 LRA at 40 °C
Up to 4.8 FLA, 28.8 LRA at 50 °C
Up to 2.1 FLA, 12.6 LRA at 60 °C

UL 60947-4-2, CSA 60947-4-2

3 AC 200 ... 300 V,

3-phase, 50 / 60 Hz: Up to 7.6 FLA, 45.6 LRA at 40 °C
Up to 4.8 FLA, 28.8 LRA at 50 °C
Up to 2.1 FLA, 12.6 LRA at 60 °C

3 AC 301 ... 480 V,

3-phase, 50 / 60 Hz: Up to 2.1 FLA, 12.6 LRA at 60 °C

Motor protection

I_e 1.5 A bis 6.8 A: Class 10 / 10 A

I_e 6.9 A bis 9.0 A: Class 5

Electronically, without thermal memory

Reset: Manual

Indicator output relay: 5 A 240 V ac Resistive

Wire connection:

60 °C / 75 °C copper conductors only

Connections

A1+, A2, X1+, X2, MAN, RES, NE, 11, 12, 14: AWG 22 - 14 Sol/Str Torque 3.46 Lb-in (0.39 Nm)

L1, L2, L3, T1, T2, T3: AWG 30 - 12 Str Torque 5-7 Lb-in (0.564-0.79 Nm)

Additional Notes:

- This device is intended for use on supply systems with a maximum voltage from phase to ground of 300 V (e.g. for a three phase-four wire system 277/480 V or on a three phase-three wire systems of 240 V), rated impulse withstand voltage of max. 4 kV
- Suitable for use on a circuit capable of delivering not more than 5000 rms symmetrical Amperes, 480 Volts maximum when protected by class CC, J or RK5 fuse rated maximum 20 A
- For use in pollution degree 2 Environment or equivalent
- The control circuits of this device shall be supplied by an isolated 24 Vdc power supply which output is protected with a fuse rated max. 4 A dc
- For installations according to Canadian National Standard C22.2 No. 14-13 (cUL Mark only) and supply voltages above 400V:
 - Transient surge suppression devices shall be installed on the line side of this equipment and shall be rated 240 V (phase to ground), 415 V (phase to phase), suitable for overvoltage category III, and shall provide protection for a rated impulse withstand voltage peak of 4 kV
 - Transient surge suppression devices shall be installed on the line side of this equipment and shall be rated 277 V (phase to ground), 480 V (phase to phase), suitable for overvoltage category III, and shall provide protection for a rated impulse withstand voltage peak of 4 kV



Technical data that is not stated in the UL-Data, can be found in the technical data section.

Characteristics

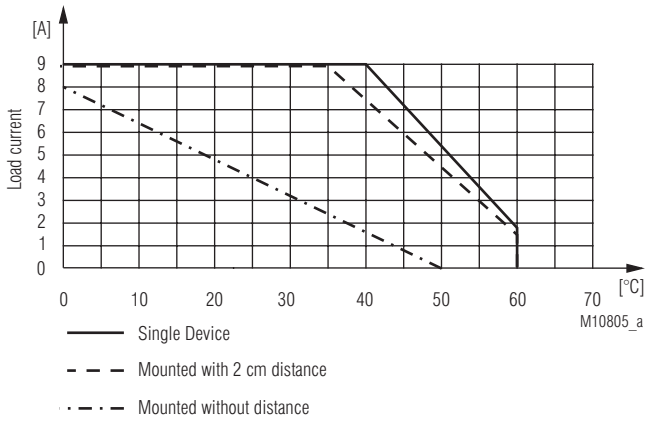

Derating curve:
 Rated continuous current depending on ambient temperature and distance
 Enclosure without ventilation slots

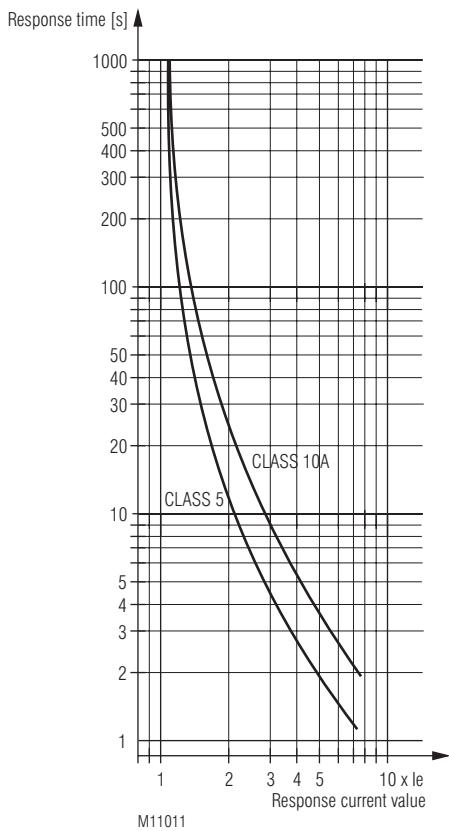

Trigger characteristics
 Motor overload protection

Standard Types

UG 9256.11/804/61 3 AC 200 ... 480 V 9.0 A
 Article number: 0066450
 • Nominal voltage: 3 AC 200 ... 480 V
 • Nominal current: 9.0 A
 • Control input R
 • Width: 22.5 mm

UG 9256.11/807/61 3 AC 200 ... 480 V 9.0 A
 Article number: 0067133
 • Nominal voltage: 3 AC 200 ... 480 V
 • Nominal current: 9.0 A
 • Main isolating
 • Control input R
 • Width: 22.5 mm

Other available variants

UG 9256.11/804	3 AC 200 ... 480 V	2 A	1.5 s	0069922
----------------	--------------------	-----	-------	---------

Variant

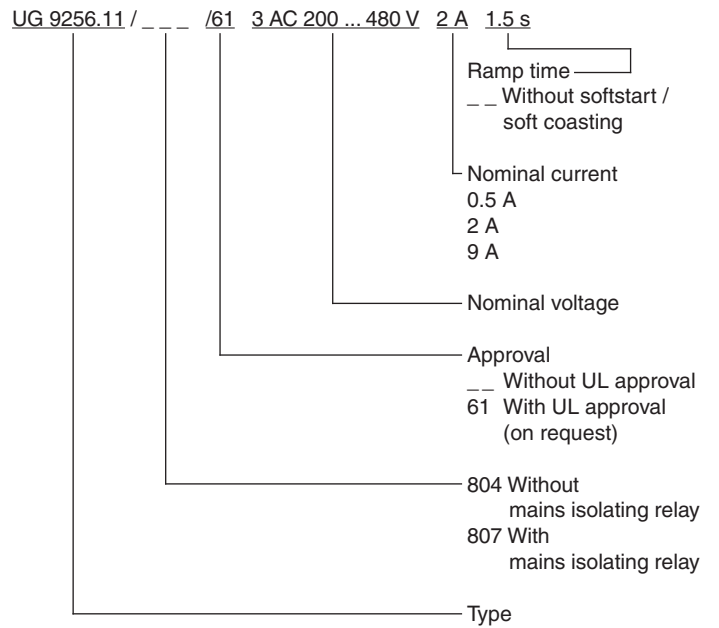

Application Example

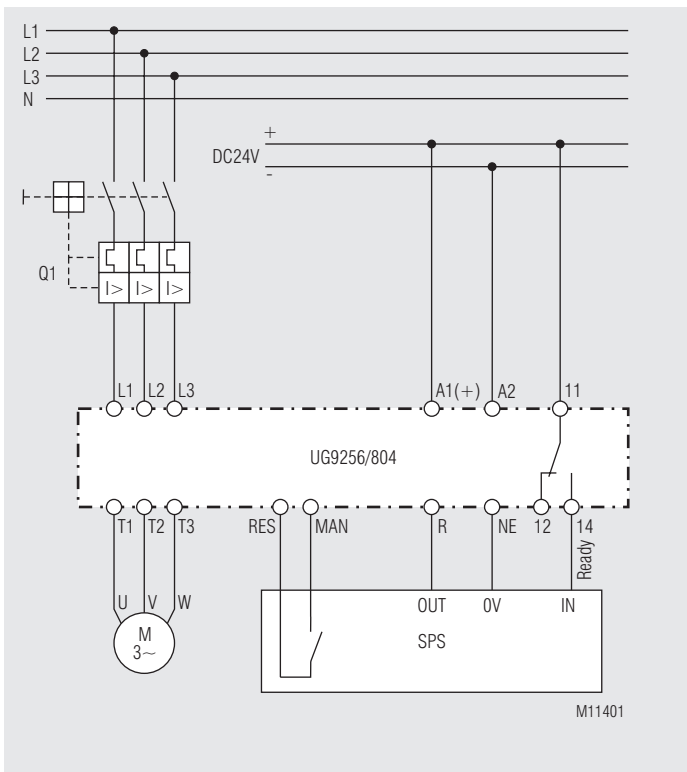

Motor control with UG 9256/804 and PLC

