

POWERSWITCH

Solid-State Relay /- Contactor With Analogue Input For Pulse Packet Control PK 9260/_4_

Translation of the original instructions

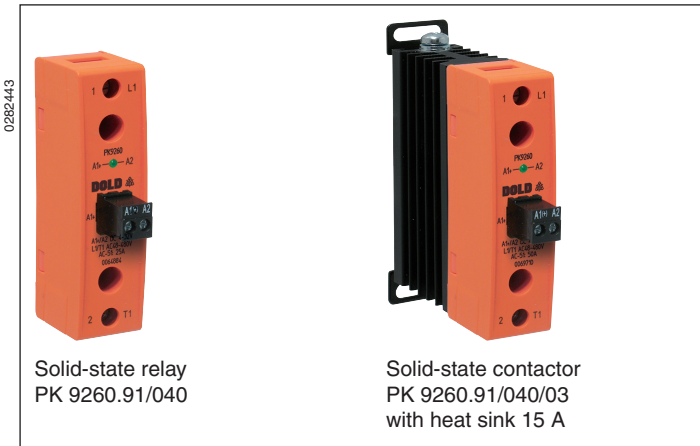

Solid-state relay PK 9260.91/040

Solid-state contactor PK 9260.91/040/03 with heat sink 15 A

Your Advantages

- Self-optimized impulse distribution with minimized cycle times
- Allows for precise temperature regulation
- Switching at zero crossing, providing outstanding EMC properties
- With heat sink for DIN-rail mounting
- Space saving, only 22.5 mm width

Features

- According to IEC/EN 60947-4-3
- AC solid-state relay / -contactor for pulse package control of heating systems
- DCB technology (direct bonding method) for excellent heat transmission properties
- Control input DC 4 ... 20 mA
- Nominal voltage AC 24 ... 240 and AC 48 ... 480 V
- Load current 10 A, 15 A, 20 A, 40 A, 50 A, 88 A AC 51
- LED status indicator for control and failure
- M4 flat terminal
- Degree of protection IP20

Product Description

The PK 9260 solid-state relay/contactor has an analogue control input DC 4 ... 20 mA with which the switch-on/switch-off ratio of the load current is controlled proportionally. The PK 9260 is available with pre-mounted heat sink (solid-state contactor) and without pre-mounted heat sink (solid-state relay).

Approvals and Markings



Circuit Diagram

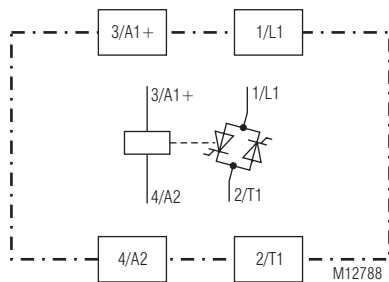

Applications

The zero-voltage switching solid-state relay with its 4 ... 20 mA analogue input for pulse packet control is ideal for controlling heating elements and infrared lamps. It enables precise temperature control and offers a wide range of applications due to its fast and silent switching, e.g. for injection moulding machines in the plastics and rubber industry, for thermoforming and packing machines or also in the food industry.

Connection Terminals

Terminal designation	Signal description
A1(+), A2	Control input
L1	Mains connection
T1	Load output
Fan connection variant /16	
Red wire	DC 24 V
Black wire	0 V

Functions

The PK 9260/_4_ solid-state relay with two antiparallel-connected thyristors is designed as a zero-voltage switch. The output of the solid-state relay is always activated at zero crossing of the sinusoidal mains voltage. After the control signal is removed, the solid-state relay switches off again at the next zero crossing of the load current.

The on/off ratio of the output is set proportionally to the control current. The control current range of 4 to 20 mA is converted into an on/off ratio of 0 to 100 %. The LED indicates the unit status.

Indications

LED A1-A2:	Yellow	Operating voltage and control current available. The flashing cycle corresponds to the on/off switching ratio specified by the control current.
	Red-fast flashes	Control current < 4 mA
	Red-slowly flashes	Control current > 21 mA

Control Circuit

Operating voltage A+1/A2	Max. 35 V DC
Load voltage	Max. 8 V (< 400 Ω at 20 mA)
Current range	DC 4 ... 20 mA
Overcurrent protection	Limit to 35 mA
Trip	5 % ± ½ cycle

Output

Load voltage AC [V]:	24 ... 240	48 ... 480
Peak reverse voltage [V]:	650	1200
Frequency range [Hz]:	47 ... 63	

Solid-state relays with factory mounted heat sink / Heat sink see table

AC-51 Load current I_{enn} [A] at $T_u = 40$ °C (acc. to EN 60947-4-3)	10	15	15*	20	30	40	40*	50	88
AC-51 Load current I_{enn} [A] at $T_u = 25$ °C (max. current at $T_j < 125$ °C):	15	25	25*	35	35	50	50*	72	88
Factory mounted heat sink	/00	/03	/03	/04	/07	/05	/05	/06	/16
Current reduction from $T_u = > 40$ °C [A / °C]	0,2	0,3	0,3	0,4	0,6	0,8	0,8	1,0	1,0
Max. overload current [A], $t = 10$ ms:	≤ 200	≤ 300	≤ 1150	≤ 400	≤ 400	≤ 620	≤ 1150	≤ 1050	≤ 1150
Load limit integral I^2t [A ² s]:	200	720	6600	800	800	1920	6600	5500	6600
Off-state leakage current [mA]	≤ 1,5								
Min. current [mA]	20								
On-state voltage at rated current [V]:	1,0	1,2	1,1	1,2	1,2	1,2	1,1	1,1	1,2
Off-state voltage dV/dt [V/μs]:	500	500	500	500	500	1000	1000	1000	1000
Rate of rise of current di/dt [A/μs]:	100	150	150	100	150	150	150	150	150

*) At variant /14 _ : High I^2t value

Solid-state relays without factory mounted heat sink / Heat sink see table

Load current I_{nenn} [A] / AC-51:	25	25*	35	50	50*	72	88
AC-51 Load current I_{nenn} [A] at $T_u = 25\text{ °C}$ (max. current at $T_j < 125\text{ °C}$):	25	25*	35	50	50*	72	88
Max. overload current [A], $t = 10\text{ ms}$:	≤ 300	≤ 1150	≤ 400	≤ 620	≤ 1150	≤ 1050	≤ 1150
Load limit integral I^2t [A^2s]:	720	6600	800	1920	6600	5500	6600
Off-state leakage current [mA]	≤ 1.5						
Min. current [mA]	20						
On-state voltage at rated current [V]:	1.2	1.1	1.2	1.2	1.1	1.1	1.2
Off-state voltage dV/dt [$V/\mu s$]:	500	500	500	1000	1000	1000	1000
Rate of rise of current di/dt [$A/\mu s$]:	150	150	100	150	150	150	150

*) At variant /14 _ : High I^2t value

Thermal Data - Solid-state relays -

Solid-state relays without heat sink Load current I_{nenn} [A] / AC-51:	25	25*	35	50	50*	72	88
Thermal resistance Junction ambient [K/W]:	10						
Thermal resistance Junction housing [K/W]:	0.55	0.25	0.48	0.36	0.25	0.35	0.25
Max. junction temperature [$^{\circ}C$]:	≤ 125						

*) At variant /14 _ : High I^2t value

Solid-state relays - Determine the heat sink

Choice according to table

The heat generated by the load current must be dissipated by a suitable heat sink. It is imperative that the junction temperature of the semiconductor is maintained for all potential environmental temperatures of under 125 °C. For this reason, it is important to keep the thermal resistance between the base plate of the solid-state relay and the heat sink to a minimum. To protect the solid-state relay effectively from excess heating, a thermally conducting paste or a graphite gasket (see Accessories) should be applied before installation to the base plate of the heat sink between semiconductor relay and heat sink.

From the table, select a suitable heat sink with the next lowest thermal resistance. Thus, it is ensured that the maximum junction temperature of 125 °C is not exceeded. The load current in relation to the environmental temperature can be seen from the table.

a)							d)						
Load current (A)	PK 9260 15 A						Load current (A)	PK 9260 50 A / 50 A Hi I ² t					
	Thermal resistance (K/W)							Thermal resistance (K/W)					
15.0	6.8	6.0	5.3	4.6	4.0	3.0	50	0.8	0.7	0.6	0.4	0.3	0.2
13.5	7.7	6.9	6.0	5.3	4.5	3.5	45	1.0	0.9	0.8	0.6	0.5	0.3
12.0	8.5	8.0	7.0	6.0	5.3	4.4	40	1.3	1.2	1.0	0.8	0.6	0.5
10.5	-	9.0	8.0	7.0	6.0	5.0	35	1.7	1.5	1.3	1.1	0.9	0.7
9.0	-	-	9.0	8.0	7.0	6.0	30	2.2	2.0	1.7	1.4	1.2	0.9
7.5	-	-	-	9.0	8.5	7.0	25	3.0	2.6	2.3	2.0	1.7	1.3
6.0	-	-	-	-	-	8.0	20	4.0	3.7	3.3	2.8	2.4	1.9
4.5	-	-	-	-	-	-	15	6.0	5.5	4.9	4.2	3.6	3.0
3.0	-	-	-	-	-	-	10	10.0	9.0	8.0	7.0	6.0	5.0
1.5	-	-	-	-	-	-	5	-	-	-	-	-	-
	20	30	40	50	60	70		20	30	40	50	60	70
	Ambient temperature (°C)							Ambient temperature (°C)					

b)							e)						
Load current (A)	PK 9260 25 A / 25A HI I ² t						Load current (A)	PK 9260 72 A					
	Thermal resistance (K/W)							Thermal resistance (K/W)					
25.0	3.0	2.7	2.3	1.9	1.5	1.0	72.0	0.7	0.6	0.5	0.4	0.3	-
22.5	3.5	3.0	2.7	2.3	1.9	1.4	64.8	0.9	0.8	0.7	0.5	0.4	0.3
20.0	4.0	3.8	3.3	2.8	2.3	1.8	57.6	1.1	1.0	0.8	0.7	0.5	0.4
17.5	5.0	4.5	4.0	3.4	2.8	2.2	50.4	1.5	1.3	1.1	0.9	0.7	0.4
15.0	6.0	5.5	4.9	4.2	3.5	2.9	43.2	1.9	1.6	1.4	1.2	1.0	0.7
12.5	7.9	7.0	6.3	5.0	4.5	3.7	36.0	2.4	2.2	1.9	1.6	1.3	1.1
10.	10.0	9.0	8.0	7.0	6.0	5.0	28.8	3.3	3.0	2.6	2.2	1.9	1.5
7.5	-	-	11.5	10.0	8.5	7.0	21.6	4.8	4.3	3.8	3.3	2.8	2.3
5.0	-	-	-	-	-	-	14.4	7.8	7.0	6.2	5.5	4.7	3.9
2.5	-	-	-	-	-	-	7.2	-	-	-	-	-	8.6
	20	30	40	50	60	70		20	30	40	50	60	70
	Ambient temperature (°C)							Ambient temperature (°C)					

c)							f)						
Load current (A)	PK 9260 35 A						Load current (A)	PK 9260 88 A					
	Thermal resistance (K/W)							Thermal resistance (K/W)					
35.0	1.6	1.4	1.2	0.9	0.7	0.4	88.0	0.6	0.5	0.4	0.3	-	-
31.5	2.0	1.7	1.4	1.2	0.9	0.6	79.2	0.7	0.6	0.5	0.4	0.3	-
28.0	2.4	2.1	1.8	1.5	1.2	0.9	70.4	0.9	0.8	0.7	0.6	0.4	0.3
24.5	3.0	2.6	2.3	1.9	1.5	1.2	61.6	1.2	1.0	0.9	0.7	0.6	0.4
21.0	3.8	3.3	2.9	2.5	2.0	1.6	52.8	1.5	1.3	1.1	1.0	0.8	0.6
17.5	4.9	4.4	3.8	3.3	2.7	2.0	44.0	2.0	1.8	1.5	1.3	1.1	0.9
14.0	6.6	5.9	5.0	4.5	3.8	3.0	35.2	2.7	2.4	2.1	1.8	1.5	1.2
10.5	9.5	8.5	7.5	6.5	5.5	4.6	26.4	3.9	3.5	3.1	2.7	2.3	1.9
7.0	-	-	-	-	-	7.6	17.6	6.3	5.7	5.0	4.4	3.8	3.1
3.5	-	-	-	-	-	-	8.8	-	-	-	9.7	8.3	7.0
	20	30	40	50	60	70		20	30	40	50	60	70
	Ambient temperature (°C)							Ambient temperature (°C)					

Solid-state contactor

Solid-state with optimised heat sink

We recommend the following combination of solid-state relay and heatsink depending on the load current and an ambient temperature of 40 °C.

If the solid-state relays are used at ambient temperature above 40 °C the load current has to be reduced according to the current reduction (A / °C see table).

Example:

Operation at $T_U = 45\text{ °C}$; heat sink for 15 A with 0.3 A / °C

Current reduction: $5\text{ °C} \times 0.3\text{ A / °C} = 1.5\text{ A}$

Max. load current: $15\text{ A} - 1.5\text{ A} = 13.5\text{ A}$

Factory mounted heat sink

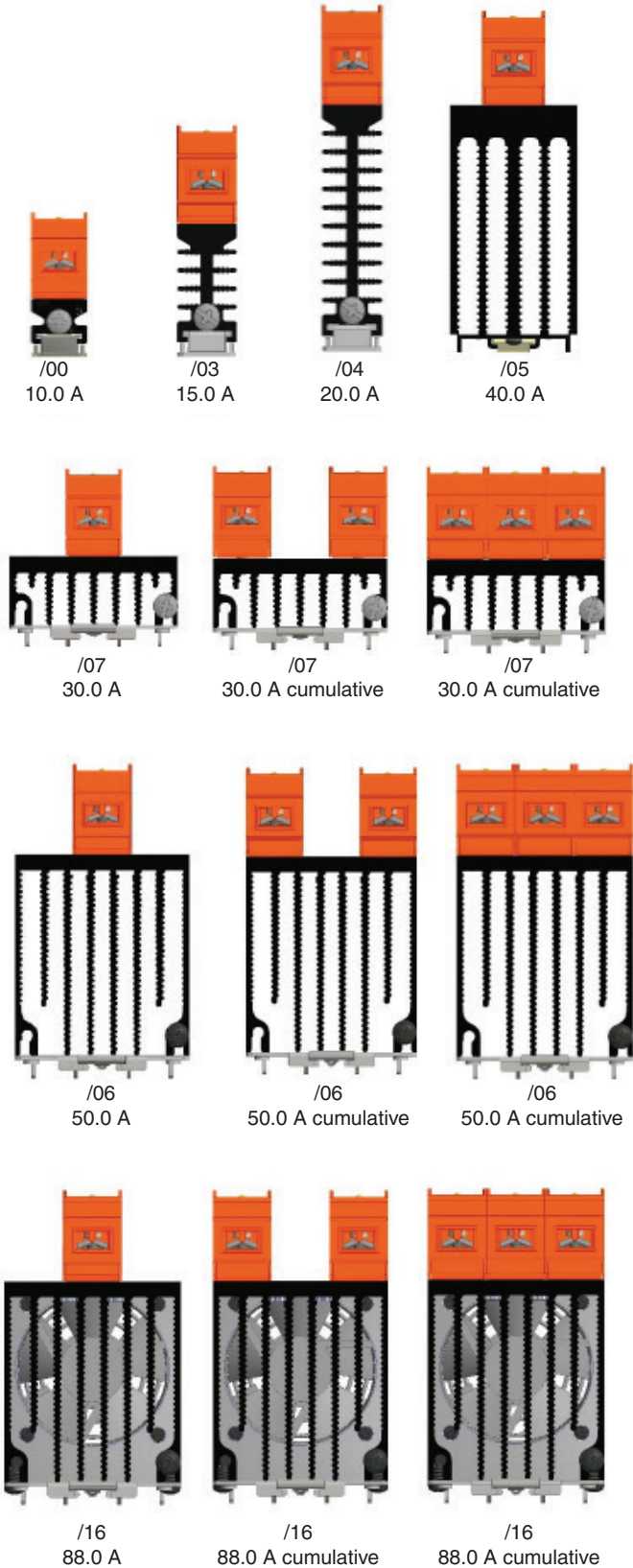

General Technical Data

For variant /16: Operating voltage fan DC 24 V
Operating mode: Continuous operation
 (Current reduction above 40 °C)

Temperature range

Operation: - 25 ... 60 °C
 Storage: - 25 ... 85 °C
 Relative air humidity: < 95 % non-condensing at 40 °C

Clearance and creepage distances

Rated impulse voltage / pollution degree: 6 kV / 3 IEC/EN 60664-1
EMC: IEC/EN 61000-6-4, IEC/EN 61000-4-1
 Electrostatic discharge (ESD): 8 kV air / 6 kV contact IEC/EN 61000-4-2
 HF irradiation: 10 V / m IEC/EN 61000-4-3
 Fast transients: 2 kV IEC/EN 61000-4-4
 Surge voltages control circuit between A1 / A2: 1 kV IEC/EN 61000-4-5
 Between output and ground: 2 kV IEC/EN 61000-4-5
 HF-wire guided: 10 V IEC/EN 61000-4-6
 Interference suppression: Limit value class A IEC/EN 60947-4-3
Degree of protection: IP 20 IEC/EN 60529
Vibration resistance: Amplitude 0.35 mm
 Frequency 10 ... 55 Hz, IEC/EN 60068-2-6
 PBT/PC flame resistant; UL 94 V0

Housing material:

Base plate: Aluminum, copper nickle-plated

Mounting screws: M4 x 20 mm

Mounting torque: 2.5 Nm

Connections load circuit / __ 0: Mounting screws M4 Pozidrive 1 PT

Mounting torque: 2.5 Nm
 Wire cross section: 2 x 1.5 ... 2.5 mm² solid or
 2 x 2.5 ... 6 mm² solid oder
 2 x 1.0 ... 2.5 mm² stranded wire with sleeve
 2 x 2.5 ... 6 mm² stranded wire with sleeve
 1 x 10 mm² stranded wire with sleeve

Connections load circuit / __ 1: Mounting screws M5

Mounting torque: 2.5 Nm
 Cable lug (DIN 46234): 5 - 2.5; 5 - 6; 5 - 10; 5 - 16; 5 - 25

Connections control circuit: Mounting screws M3 Pozidrive 2 PT

Mounting torque: 0.6 Nm
 Wire cross section: 1 x 0.5 ... 2.5 mm² solid or
 2 x 0.5 ... 1.0 mm² solid or
 1 x 0.5 ... 2.5 mm² stranded wire with sleeve
Connections control circuit: Cage clamp terminals
 Wire cross section: 0.2 ... 2.5 mm² solid or
 0.25 ... 2.5 mm² stranded wire with sleeve

Nominal insulation voltage

Control circuit – load circuit: 4 kV_{eff.}
 Load circuit – base plate: 4 kV_{eff.}
 Overvoltage category: III

Weight

Without heat sink: Approx. 80 g

With heat sink:

Load current

10 A /00 Approx. 150 g
 15 A /03 Approx. 225 g
 20 A /04 Approx. 305 g
 30 A /07 Approx. 475 g
 40 A /05 Approx. 575 g
 50 A /06 Approx. 785 g
 88 A /16 Approx. 895 g

Dimensions

Width x height x depth

Without heat sink

With screw terminals: 22.5 x 85 x 50.0 mm
 With cable lug terminals: 22.5 x 139 x 50.0 mm

With heat sink

Load current

10 A /00 22.5 x 99 x 68.4 mm
 15 A /03 22.5 x 99 x 92.0 mm
 20 A /04 22.5 x 99 x 131.0 mm
 30 A /07 67.5 x 136 x 77.4 mm
 40 A /05 45.0 x 105 x 135.0 mm
 50 A /06 67.5 x 136 x 127.0 mm
 88 A /16 67.5 x 161.6 x 127.0 mm

Standard Type

PK 9260.91/040 /03 AC 48 ... 480 V 15 A DC 4 ... 20 mA
 Article number: 0069709
 • Load voltage: AC 48 ... 480 V
 • Load current: 15 A
 • Current range: DC 4 ... 20 mA
 • Width: 22.5 mm

Variants

PK 9260 .91 / _ 4 _ / _ _ / 001

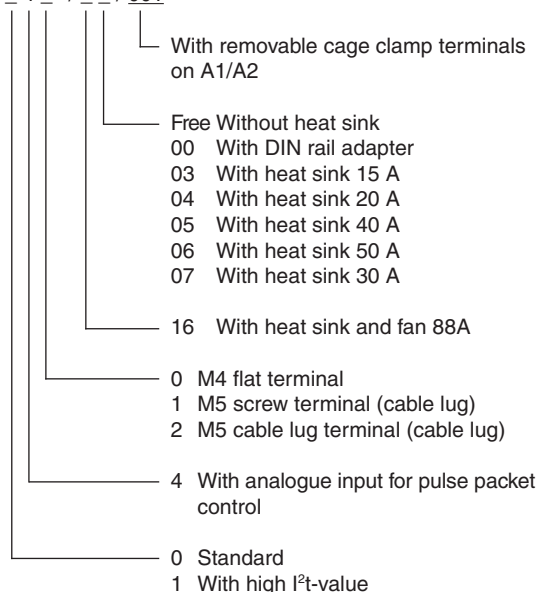

Ordering Examples for Variants

PK 9260.91 / 1 4 0 /03 AC 48 ... 480 V 15 A DC 4 ... 20 mA

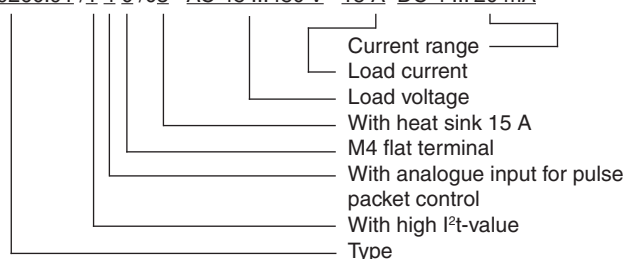

Variants

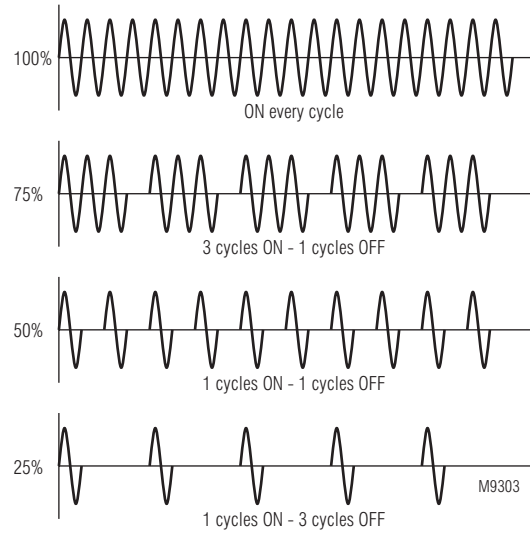
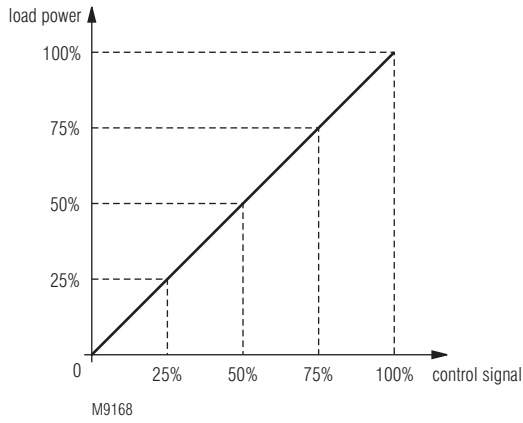

Application example

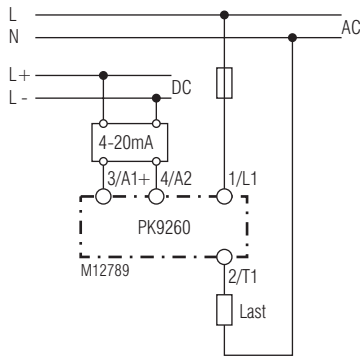

Operation Notes

EMC disturbance during operation has to be reduced by corresponding measures and filters. If several solid-state relays are mounted together sufficient cooling and ventilation has to be provided.

Safety Notes For Variants With Fan



Risk of fire or other thermal hazards!

Danger to life, risk of serious injuries or property damage.

- The device has no overtemperature alarm. If the fan fails, the unit may overheat and become a fire hazard.
- The user must take precautions to detect a fan failure.

Dimensions

Flat terminals
PK 9260.91/_4_

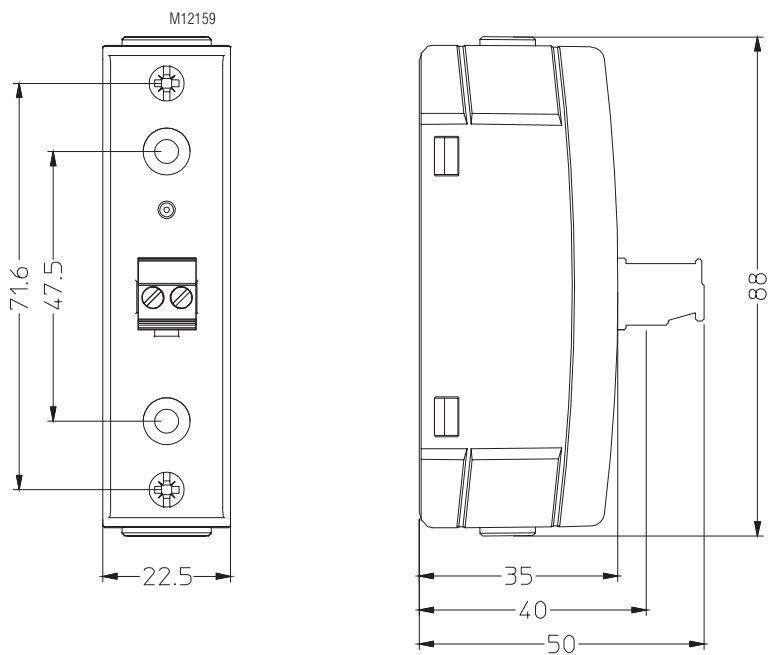

PK 9260.91/_4_/00

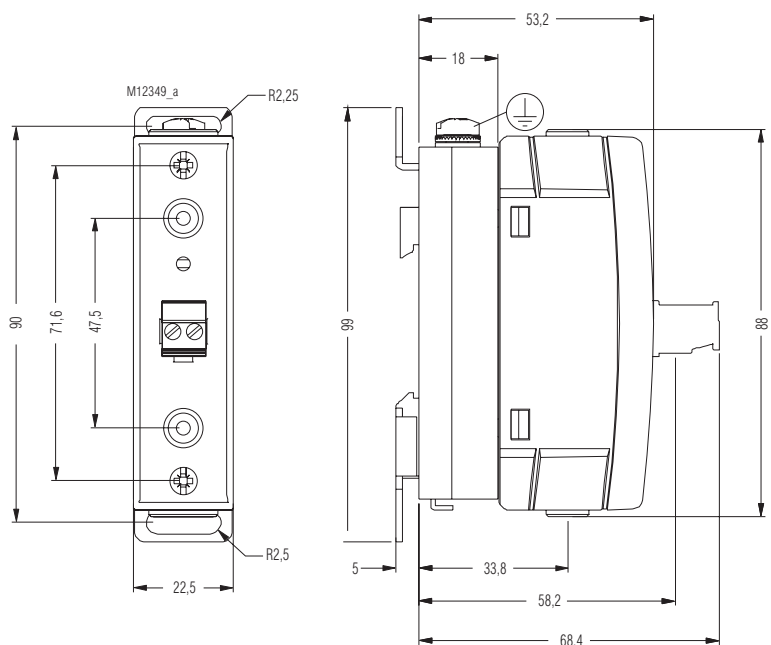

PK 9260.91/_4_/03

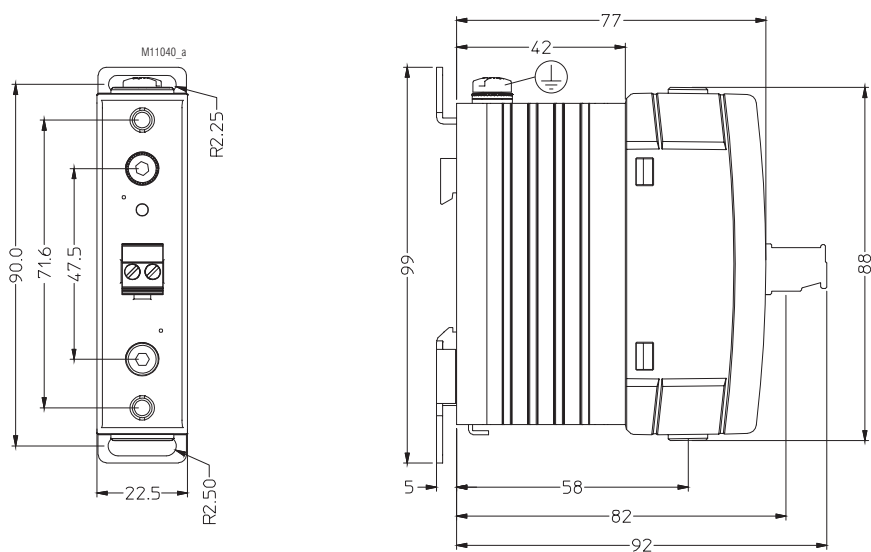

Dimensions

PK 9260.91/_4_/04

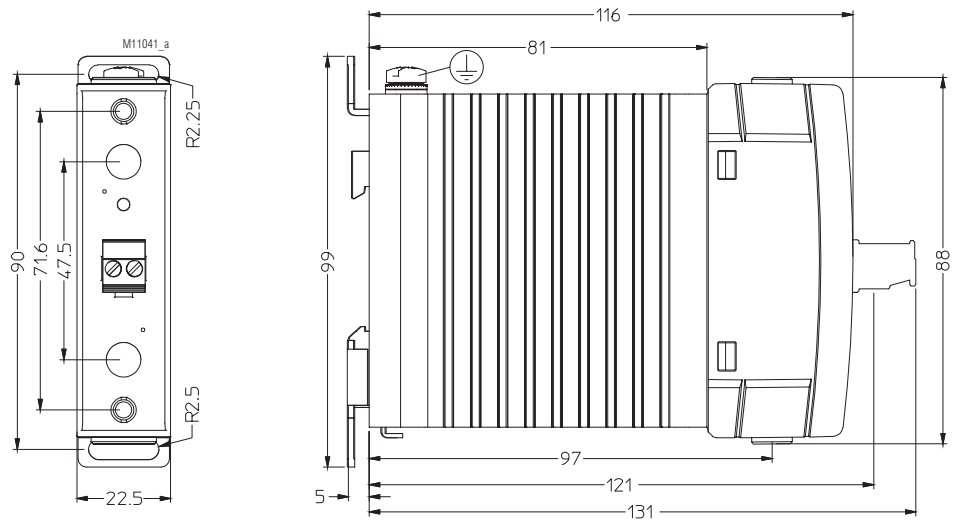

PK 9260.91/_4_/05

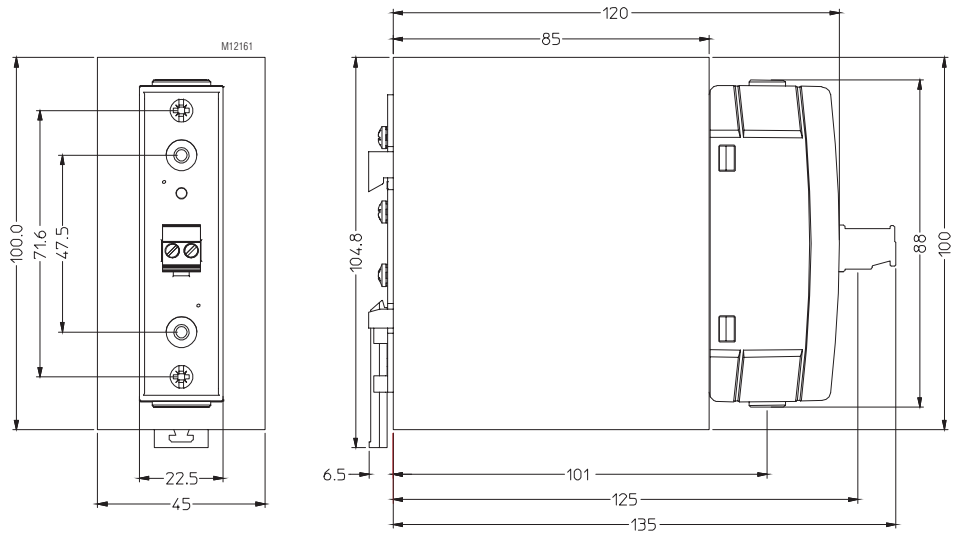

PK 9260.91/_4_/06

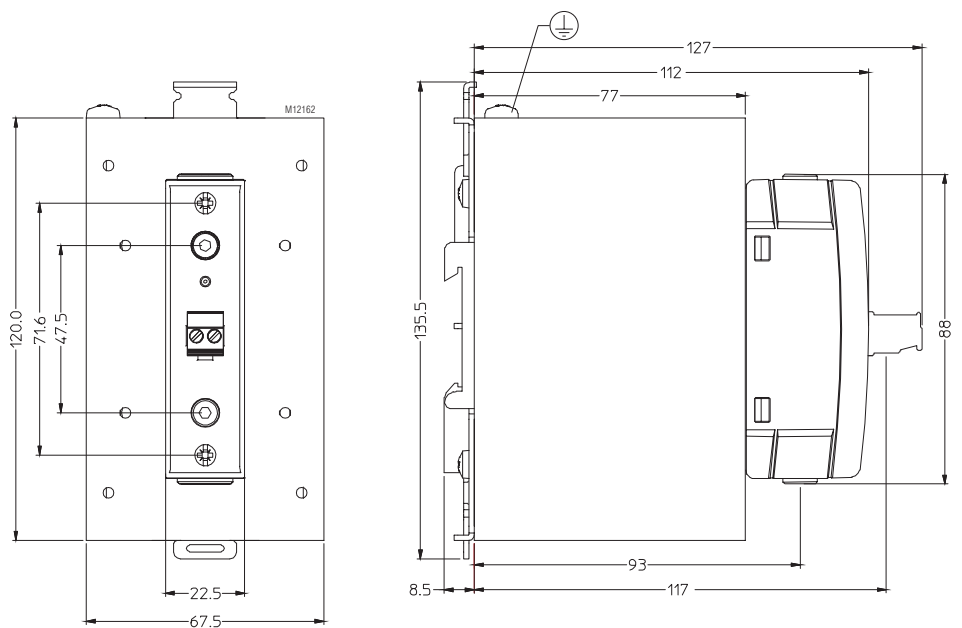

Dimensions

PK 9260.91/_4_/07

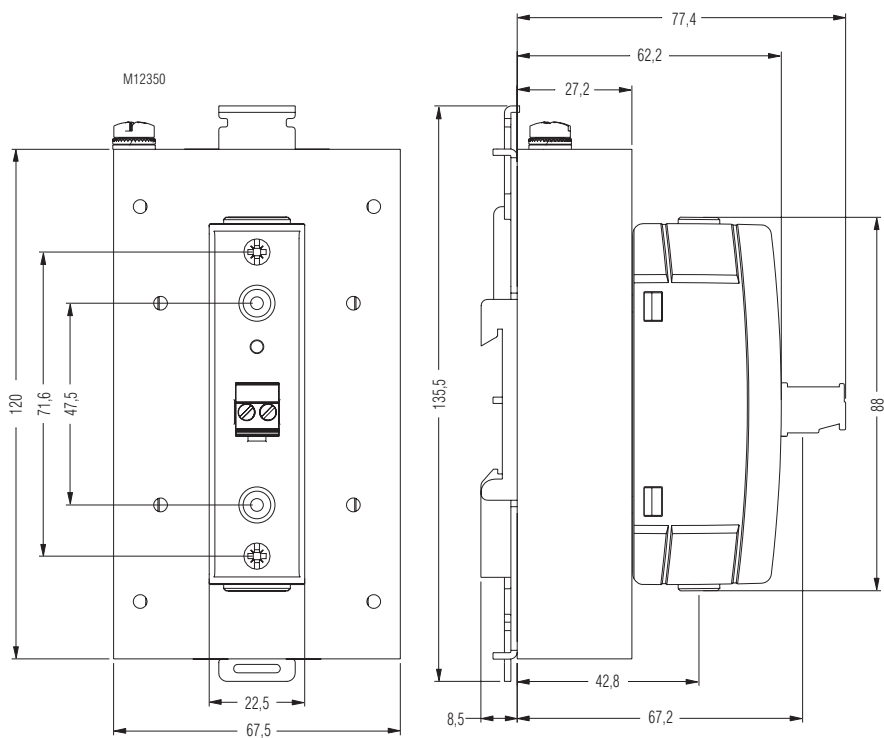

PK 9260.91/_4_/16

